

DATE :	Dec/28/14'
CMS P/N :	N/A
Dwg No:	N/A
CUST. P/N :	USB3.1 C/1-C/1-500mm
CUSTOMER :	
DESCRIPTION	USB3.1 C/1-C/1-500mm
APPROVE:	

REV.	DATE	DESCRIPTION	BY
1.0	Dec/28/14'	D3160	Eve

CONFIGURATION

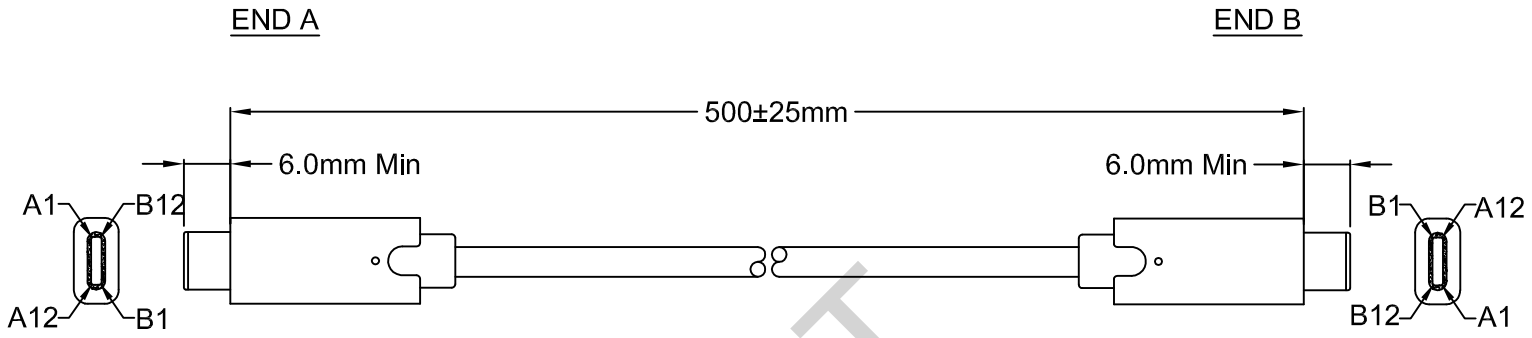

SPECIFICATION OF MATERIAL

1. END A			
CONT. PLATING	-	MOLD No.	-
CONNECTOR TYPE	USB 3.1 C TYPE Male Black Insulator, Nickel plated shell		T. SCREW
2. END B			
CONT. PLATING	-	MOLD No.	-
CONNECTOR TYPE	USB 3.1 C TYPE Male Black Insulator, Nickel plated shell		T. SCREW
3. WIRES			
WIRE GAUGE	-	LENGTH	490+15-0mm
CONDUCTORS	-	COLOR	Black
JACKET MAT'L	PVC	INS. MAT'L	-
		SHIELD'G	-
		UL/CSA	-
		WIRE O.D.	-

4. CONNECTOR PIN OUT

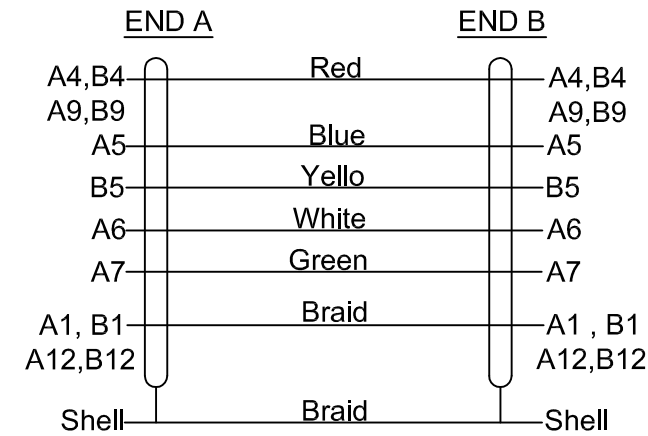

5. SPECIAL REQUIREMENTS

- Product requirement for Green environment protection: RoHS.
- Overmold PVC is 45P Black (RoHS).