

DATE :	Dec/28/14'
CMS P/N :	N/A
Dwg No:	N/A
CUST. P/N :	Micro USB 3.0 B-USB3.1 C-500mm
CUSTOMER :	
DESCRIPTION	Micro USB 3.0 B-USB3.1 C-500mm
APPROVE:	

REV.	DATE	DESCRIPTION	BY
1.0	Dec/28/14'	D3160	Eve

## CONFIGURATION

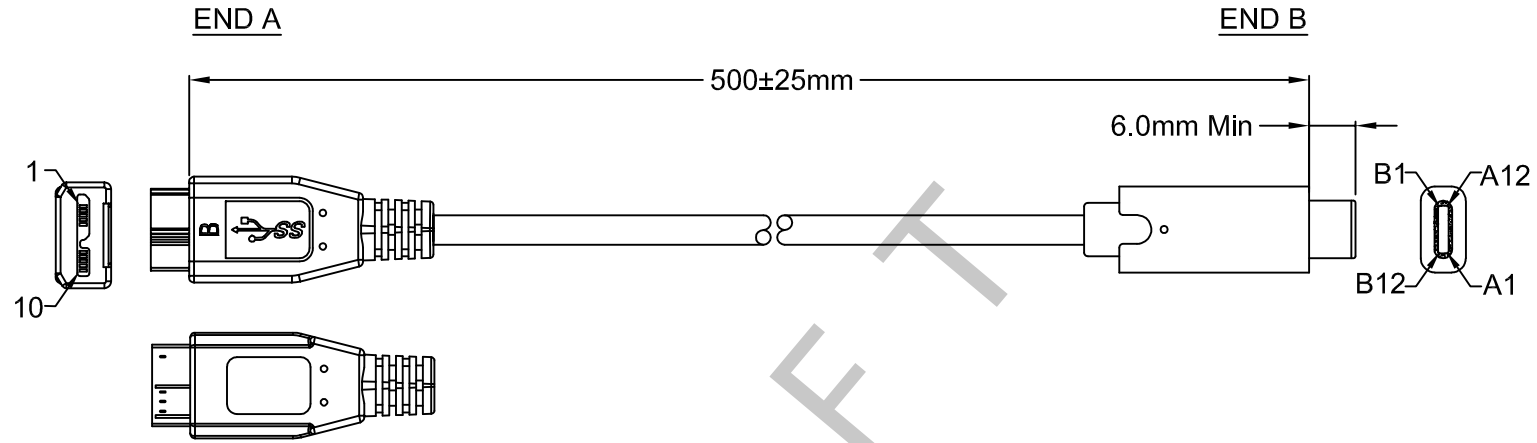

## SPECIFICATION OF MATERIAL

<b>1. END A</b>			
CONT. PLATING	-	MOLD No.	-
CONNECTOR TYPE	Micro USB 3.0 B TYPE Male Black Insulator, Nickel plated shell		T. SCREW
<b>2. END B</b>			
CONT. PLATING	-	MOLD No.	-
CONNECTOR TYPE	USB 3.1 C TYPE Male Black Insulator, Nickel plated shell		T. SCREW
<b>3. WIRES</b>			
WIRE GAUGE	-	LENGTH	490+15-0mm
CONDUCTORS	-	COLOR	Black
JACKET MAT'L	PVC	INS. MAT'L	-
		SHIELD'G	-
		UL/CSA	-
		WIRE O.D.	-

## 4. CONNECTOR PIN OUT

END A		END B
1	Red	A4, B4, A9, B9
3	White	A6
2	Green	A7
10	Blue	A2
9	Black	A3
7	Orange	B11
6	Brown	B10
5,8	Braid	A1, B1, A12, B12
Shell	Braid	Shell

## 5. SPECIAL REQUIREMENTS

- 5.1 Product requirement for Green environment protection: RoHS.
- 5.2 Overmold PVC is 45P Black (RoHS).