

DATE :	Dec/28/14'
CMS P/N :	N/A
Dwg No:	N/A
CUST. P/N :	USB3.1 A/1-C/1-500mm
CUSTOMER :	
DESCRIPTION	USB3.1 A/1-C/1-500mm
APPROVE:	

REV.	DATE	DESCRIPTION	BY
1.0	Dec/28/14'	D3160	Eve

## CONFIGURATION

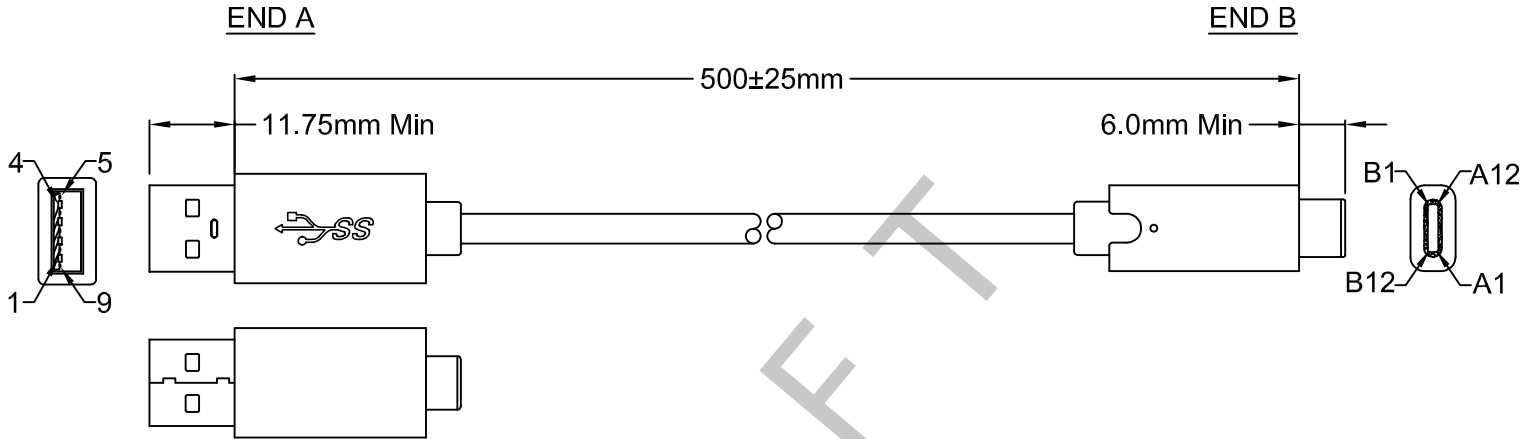

## SPECIFICATION OF MATERIAL

### 1. END A

CONT. PLATING	-	MOLD No.	-	SHIELD'G	-
CONNECTOR TYPE	USB 3.1 A TYPE Male Blue Insulator, Nickel plated shell			T. SCREW	-

### 2. END B

CONT. PLATING	-	MOLD No.	-	SHIELD'G	-
CONNECTOR TYPE	USB 3.1 C TYPE Male Black Insulator, Nickel plated shell			T. SCREW	-

### 3. WIRES

WIRE GAUGE	-	LENGTH	490+15-0mm	SHIELD'G	-
CONDUCTORS	-	COLOR	Black	UL/CSA	-
JACKET MAT'L	PVC	INS. MAT'L	-	WIRE O.D.	-

### 4. CONNECTOR PIN OUT

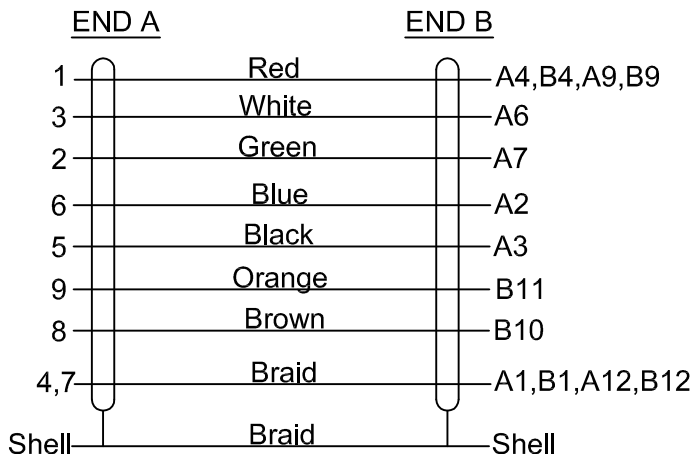

### 5. SPECIAL REQUIREMENTS

- 5.1 Product requirement for Green environment protection: RoHS.
- 5.2 Overmold PVC is 45P Black (RoHS).