

DATE :	Aug/02/11'
P/N :	B0106202
Dwg No:	A06491
CUST. P/N :	USB3C-A/1-CS/1-A-0
CUSTOMER :	
DESCRIPTION	USB3C-A/1-CS/1-A-0
APPROVE:	

REV.	DATE	DESCRIPTION	BY
1.0	Aug/02/11'	D2503	Catherine
1.1	Dec/19/12'	R-2201	Eve

CONFIGURATION

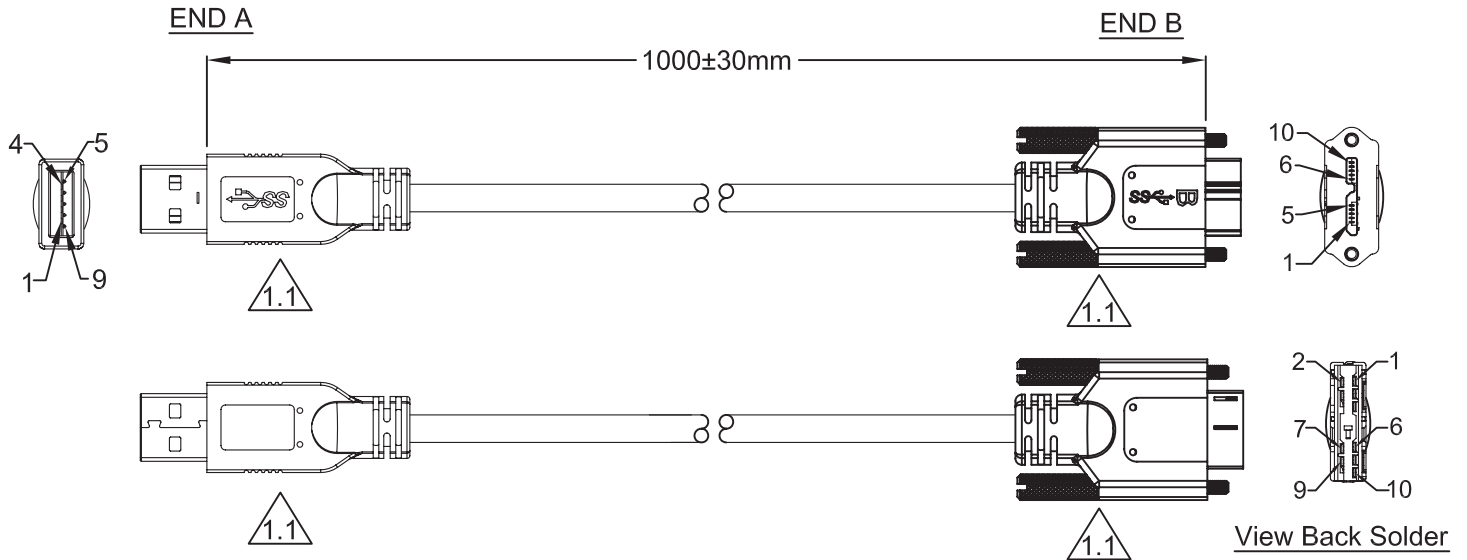

SPECIFICATION OF MATERIAL

1. END A

CONT. PLATING: Gold 30u" MOLD No. CMS-USB40 SHIELD'G: -

CONNECTOR TYPE: USB-9MASS30NBU T. SCREW: -

2. END B

CONT. PLATING: Gold 30u" MOLD No. CMS-USB41 SHIELD'G: -

CONNECTOR TYPE: USB-10MDSS30NB T. SCREW: Jack Screw M2 Size :4.00x33.00x7.00

3. WIRES

WIRE GAUGE: 28Awg&28Awg&24Awg LENGTH: 1000+20-0mm SHIELD'G: AB

CONDUCTORS: (1TP+MAE)x2+(1TP+AL)+2C COLOR: Blue (301U) UL/CSA: UL2725 (USB3.0)

JACKET MAT'L: PVC INS. MAT'L: FM-SKIN-PE&FM-PE&SR-PVC WIRE O.D.: 5.5mm

4. CONNECTOR PIN OUT

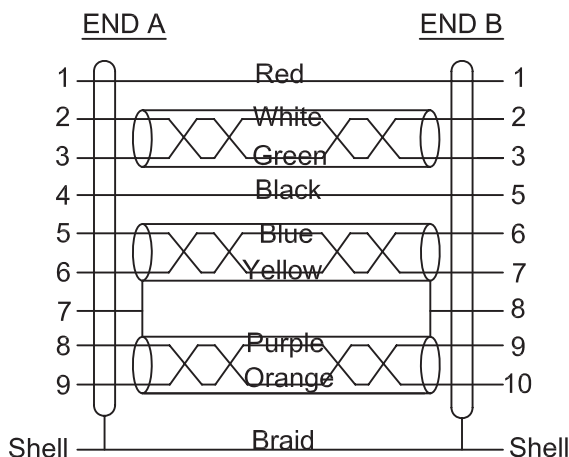

5. SPECIAL REQUIREMENTS

5.1 Product requirement for Green environment protection:RoHS.

5.2 Overmold PVC is 45P Blue (Pantone No.:301U)(RoHS).

*** Standard Product**