

Electronic Links international inc

DATE :	Dec/02/09'
CMS P/N :	B0106053
Dwg No:	A05773
CUST. P/N :	USB3C-A/1-A/1-A-0
CUSTOMER :	
DESCRIPTION	USB3C-A/1-A/1-A-0
APPROVE:	

REV.	DATE	DESCRIPTION	BY
1.0	Dec/02/09'	D2246	Catherine

CONFIGURATION

RoHS

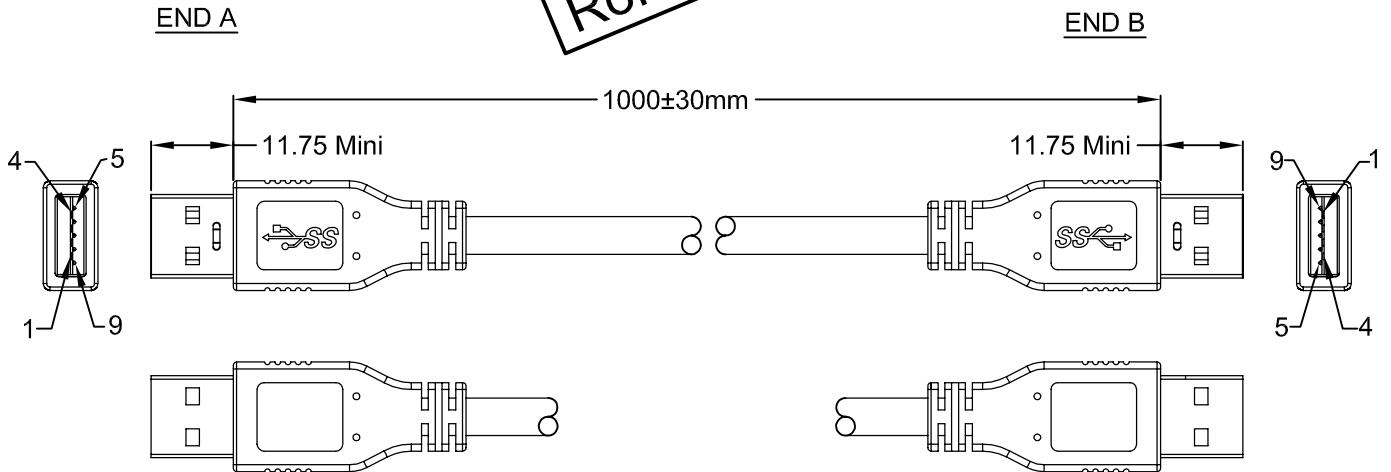

SPECIFICATION OF MATERIAL

1. END A

CONT. PLATING MOLD No. SHIELD'G

CONNECTOR TYPE T. SCREW

2. END B

CONT. PLATING MOLD No. SHIELD'G

CONNECTOR TYPE T. SCREW

3. WIRES

WIRE GAUGE LENGTH SHIELD'G

CONDUCTORS COLOR UL/CSA

JACKET MAT'L INS. MAT'L WIRE O.D.

4. CONNECTOR PIN OUT

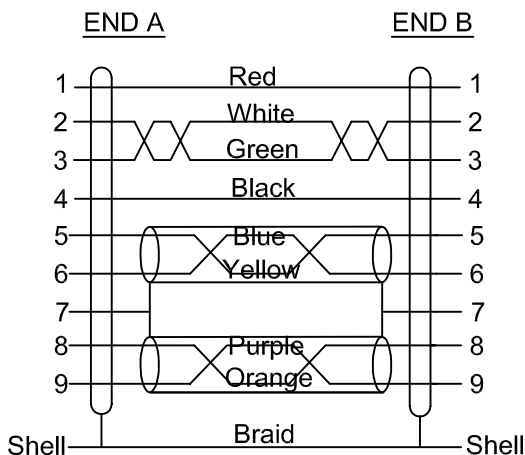

5. SPECIAL REQUIREMENTS

5.1 Product requirement for Green environment protection:RoHS.

5.2 Overmold PVC is 60P Blue (Pantone No.:301U)(RoHS).

5.3 ELECTRIC TESTING:

1. 100% OPEN & SHORT TESTING
2. INSULATION RESISTANCE: $\geq 20M\Omega$
3. CONDUCTOR RESISTANCE: $\leq 5\Omega$
4. VOLTAGE: 500V DC/0.1S

* Standard Product