

The Electronic Links 1394 IDB in T.H. is in compliance with IEEE specification 2004024. The typical application is for automotive networking.

Overview

Electronic Links 1394 IDB socket in T.H. is in compliance with the IEEE 2004024 Specification.

This configuration is in addition to the SMT type also available from ELII.

These connectors are used to interface with the cable assemblies also produced by ELI.

These sockets are also in compliance with the IEEE 2001018 document.

The connector uses the light sources from Firecomms (www.firecomms.com)

Specifications

Data Rate:	Up to 250 Mbps
Distance:	Up to 18 meters
Mating:	Manual / 45 N max
Unmating:	Manual / 45 N max
Latch Retention:	100 N min

Features

- Compliant with the IEEE 2001018 Document
- Compliant with the IEEE 2004024 Document
- RoHS compliant
- No Electromagnetic Interference (EMI)

1394 IDB Socket, T.H.

PART NUMBER

ELII-1394-S-X-Y-Z

P = PLASTIC LEGS
M = METAL LEGS

T = THRU HOLE
S = SMT

N = NEUTRAL KEY, BROWN
A = TYPE A KEY, BLACK
B = TYPE B KEY, GREY
C = TYPE C KEY, WHITE

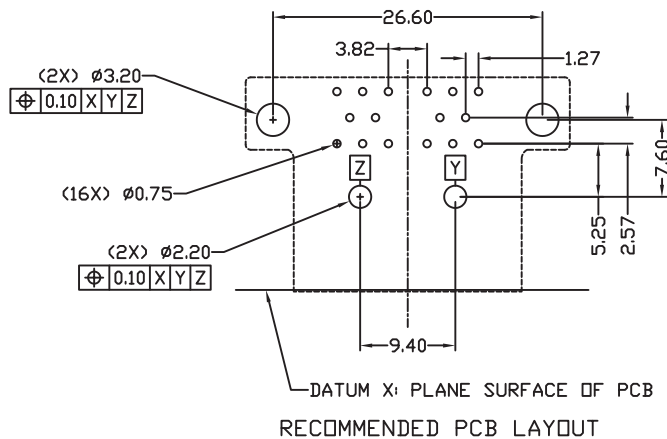
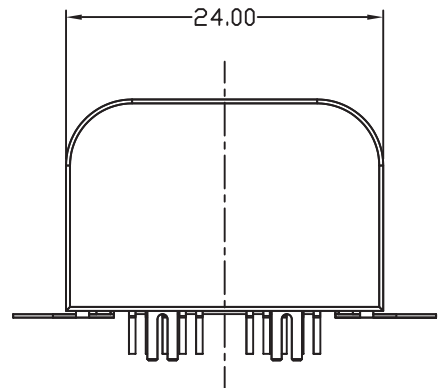
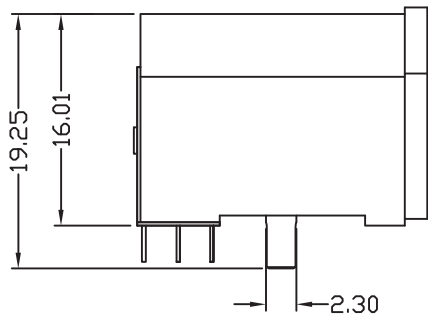
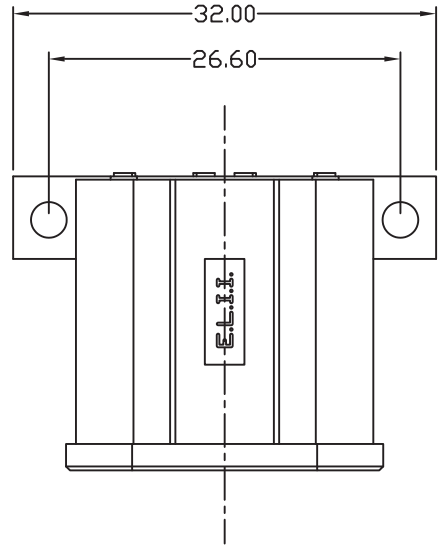

ElectronicLinks
international inc

(c) Copyright 2006 Electronic Links

Electronic Links assumes no responsibility for inaccuracies or omissions in the information contained in this document. Specifications are subject to change without notice. No patent rights are granted to any of the circuits described herein.

20 Hawley Street | Fifth Floor, East Tower | Binghamton, NY 13901 USA

Tel: 607.761.9952 | Fax: 607.772.0118

Email: info@electronic-links.com | Web: www.electronic-links.com